

**PLEASE READ ENTIRE INSTRUCTIONS BEFORE PROCEEDING.
INSTALLATION MUST COMPLY WITH ALL LOCAL CODES.**

IMPORTANT: Save these instructions for the Local Electrical Inspector's use.

INSTALLER: Please leave these Instructions with this unit for the owner.

OWNER: Please retain these instructions for future reference.

SAFETY WARNING: Turn off power circuit at the service panel and lock out panel, before wiring this unit.

IMPORTANT SAFETY INSTRUCTIONS

WARNING - TO REDUCE THE RISK OF FIRE, ELECTRIC SHOCK, OR INJURY TO PERSONS, OBSERVE THE FOLLOWING:

CAUTION: FOR GENERAL VENTILATING USE ONLY. DO NOT USE TO EXHAUST HAZARDOUS OR EXPLOSIVE MATERIALS OR VAPORS.

- A. Use this unit only in the manner intended by the manufacturer. If you have questions, contact the manufacturer.
- B. Before installing, servicing or cleaning the unit, switch power off at service panel and lock service panel to prevent power from being switched on accidentally
- C. Installation work and electrical wiring must be done by qualified person(s) in accordance with all applicable codes & standards, including fire-rated construction.

- D. Sufficient air is needed for proper combustion and exhausting of gases through the flue (chimney) of fuel burning equipment to prevent backdrafting. Follow the heating equipment manufacturers guideline and safety standards such as those published by the National Fire Protection Association (NFPA), and the American Society for Heating, Refrigeration and Air Conditioning Engineers (ASHRAE), and the local code authorities.

E. Due to size and weight of this unit, **two installers** are recommended.

F. When cutting or drilling into wall or ceiling, do not damage electrical wiring and other hidden utilities.

G. To properly exhaust air, be sure to duct air outside. **DO NOT** vent exhaust air into

spaces within walls, ceilings, attics, crawl space or garages.

H. WARNING - TO REDUCE THE RISK OF FIRE, USE ONLY METAL DUCTWORK.

I. Install this hood in accordance with all requirements specified by the manufacturer of your cooktop / range.

J. Install this hood using required clearance from cooking surface to combustible material specified in cooktop installation instructions.

continued next page

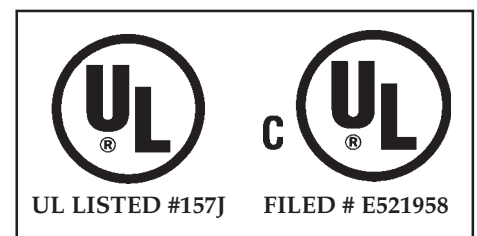

IMPORTANT SAFETY INSTRUCTIONS

WARNING - TO REDUCE THE RISK OF A RANGE TOP GREASE FIRE:

- a) Never leave surface units unattended at high settings. Boilovers cause smoking and greasy spillovers that may ignite. Heat oils slowly on low or medium settings.
- b) Always turn hood ON when cooking at high heat or when cooking flaming foods.
- c) Clean ventilating fans frequently. Grease should not be allowed to accumulate on fan or filter.
- d) Use proper pan size. Always use cookware appropriate for the size of the surface element.

WARNING: - TO REDUCE THE RISK OF INJURY TO PERSONS IN THE EVENT OF A RANGE TOP GREASE FIRE, OBSERVE THE FOLLOWING:

- A. SMOTHER FLAMES with a close-fitting lid, cookie sheet, or metal tray, then turn off the burner. BE CAREFUL TO PREVENT BURNS. If the flames do not go out immediately, EVACUATE AND CALL THE FIRE DEPARTMENT.
- B. NEVER PICK UP A FLAMING PAN - You may be burned.
- C. DO NOT USE WATER, including wet dishtowels or towels - a violent explosion will result.

D. Use an extinguisher ONLY if:

- 1) You know you have a Class ABC extinguisher, and you already know how to operate it.
- 2) The fire is small and contained in the area where it started.
- 3) The fire department is being called.
- 4) You can fight the fire with your back to an exit.

Parts included with your Professional Hood:

- Hood Canopy Assembly
- Rough-in Plate
- Transition
- Screws (may not need all screws depending on hood size) 17 pcs - #10 x 1"
- Installation Instructions
- Care & Use
- Filters (2, 3 or 4 depending on hood size)
- Grease Trough (1 or 2 depending on hood size)
- Pig Tail Assembly (Discard if hood is installed with integral ventilator)

To be purchased separately:

Ventilator Motor Models: choose one of the following:

- VTN1000Q - 1000CFM, 3 speed, integral ventilator
- VTR1000Q - 1000 CFM 3 speed, remote ventilator
- VTR1400Q - 1400 CFM, 3 speed, remote ventilator

Halogen Bulbs (2) size R20, 50 watt maximum.
(3 bulbs for hoods of 48" or longer)

Duct Tape 2" wide

Wall Anchors (if needed)

1/2" diameter conduit

Keep Hot Shelf Accessory-KHS (Optional)

Heat Lamp Bulbs - (2) size R40, 250 watt maximum, infra-red

Wire Nuts

PROFESSIONAL WALL HOOD SPECIFICATIONS

- Construction - Stainless Steel
- Height - 18"
- Depth (Overall) - 27"
- Depth (Top) - 12"
- Width - 30", 36", 42", 48" & 54"

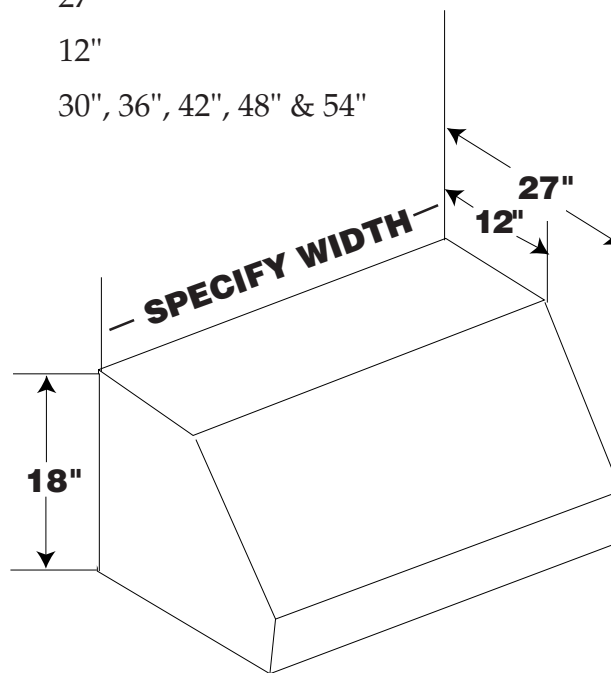

TYPICAL INSTALLATION

The Professional Wall Hood can be installed with integrated ventilator assembly model #VTN1000Q or with remote ventilator model #VTR1000Q or #VTR1400Q. See Figures 1 and 2.

Note: Ventilator assembly is not included in the hood assembly. (It must be purchased separately)

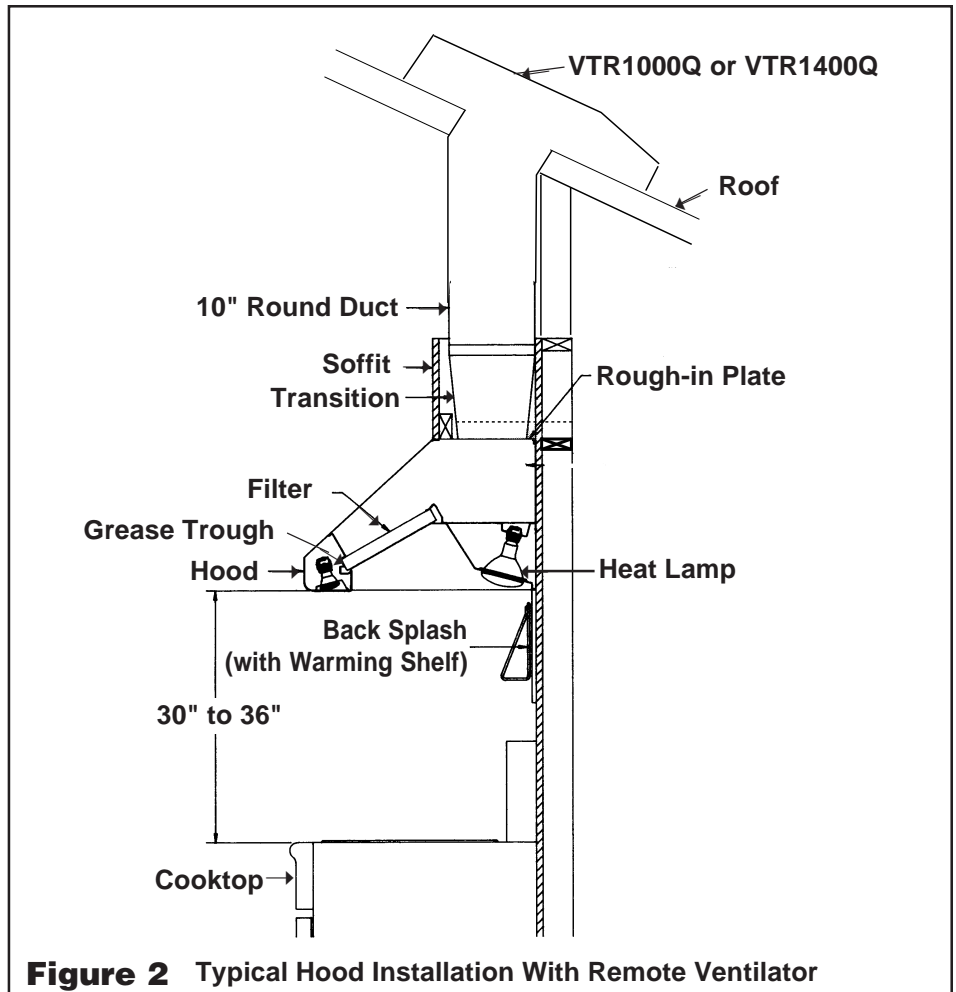
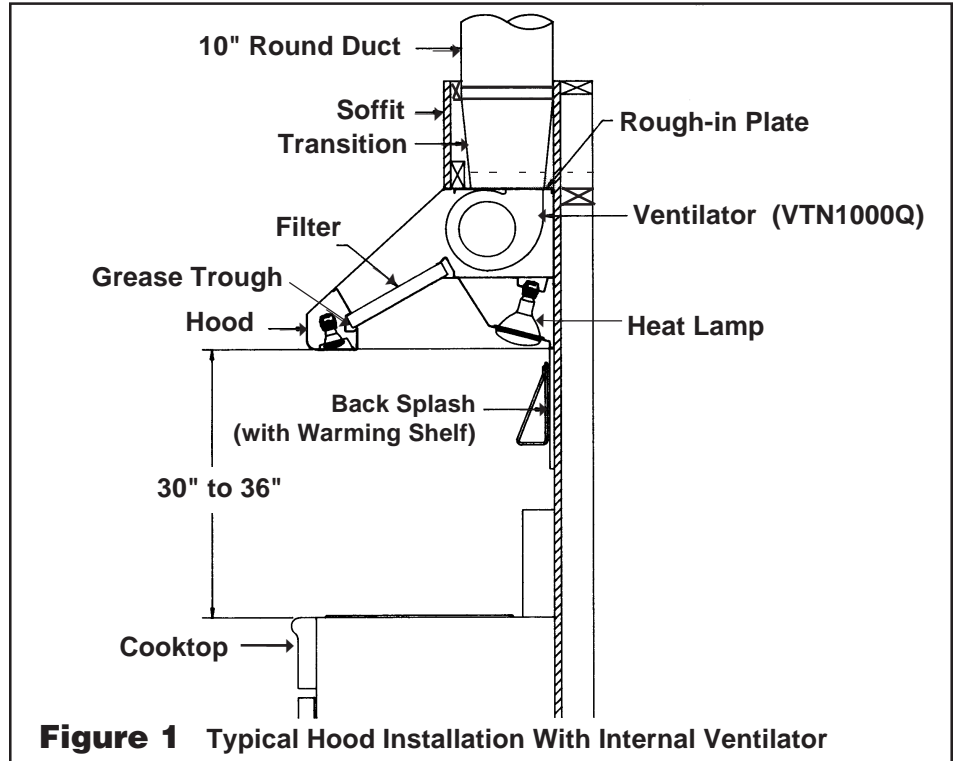

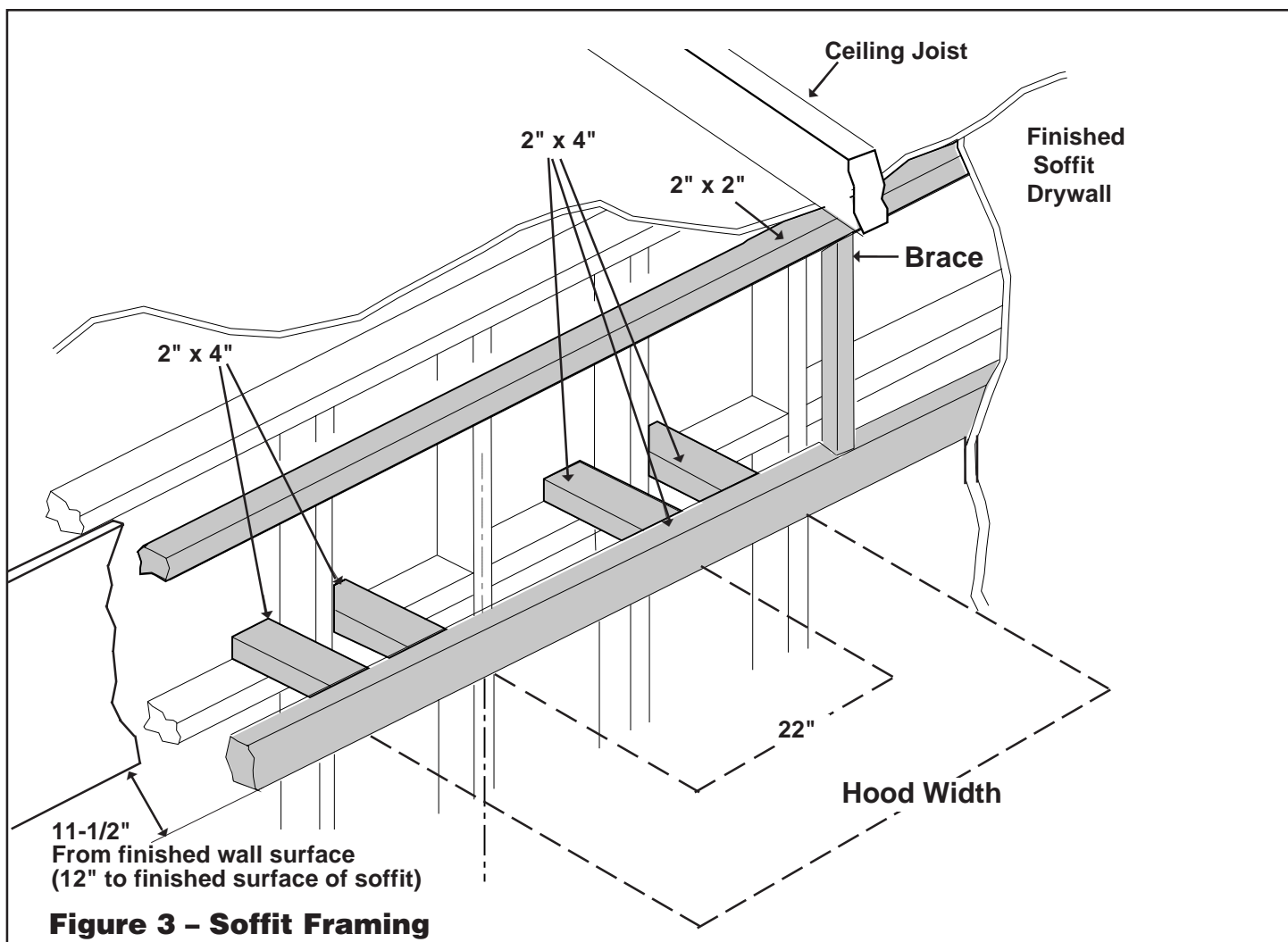

STEP 1. SOFFIT FRAMING

(NOTE: A MINIMUM SOFFIT OPENING OF 10" by 22" IS REQUIRED TO ACCOMMODATE THE DUCT WORK.)

1. Locate and mark the center line of the hood location. Nail two 2" x 4"s (wide side down) to the wall stud or framing so that their inner edges are 22" apart.
2. **Hood Size 30"**: Skip step 2
Hood Size 36": Nail a set of 2 x 2s so their outer edges are the hood width apart. (36" width)

3. **Hood Sizes 42" to 54"**: Nail a second set of 2" x 4"s (wide side down) so that the outer edges are the hood width apart. (e.g. 42" to 54" width)
3. Nail 2" x 4" wood on the ends of 2" x 4"s, making the depth of the soffit 11-1/2" from the finished drywall. See Figure 3.
4. Nail 2" x 2" wood to the ceiling joist as shown in Figure 3.
5. Install bracing as needed between 2" x 2" and 2" x 4". See Figure 3.

NOTE: For any kitchen ceiling height, a rigid structural framing must be installed to support the weight of the hood.

CAUTION:

Soffit framing must be structurally tied together and tied to ceiling joists to provide adequate strength to support the weight of the hood and integral ventilator, if used.

STEP 2. INSTALL ROUGH-IN PLATE

1. The hood assembly is shipped with the rough-in plate and transition attached.

Note: The transition is shipped upside down in the hood assembly and must be removed and reinstalled (See Steps 2 through 4).

2. To detach the rough-in plate/transition from the hood assembly, remove the four (4) screws on the top and four (4) screws on the back of the assembly as shown in Figure 4.

3. Detach the transition from the rough-in plate by removing four (4) screws. The shipping screws are needed for re-installing the transition to the rough-in plate.

4. Secure transition to top of the rough-in plate, using four (4) screws provided. Use duct tape to seal the joints of the transition and the top of the rough-in plate. See Figure 5.

5. Mark the center line of the rough-in plate and align with center line of the soffit. See Figure 6.

6. Install rough-in plate to the soffit, using four (4) #10x1" screws packed with the plate. (See example for 36" hood in Figure 6 on Page 6). These screws must be driven into the soffit framing.

7. Secure the back side of the rough-in plate to the finished drywall. Use wall anchors for the drywall if the two (2) screws do not hit the wall stud.

8. **30" hood model only:** Drill clearance hole through wood framing for conduit wires and strain relief connector.

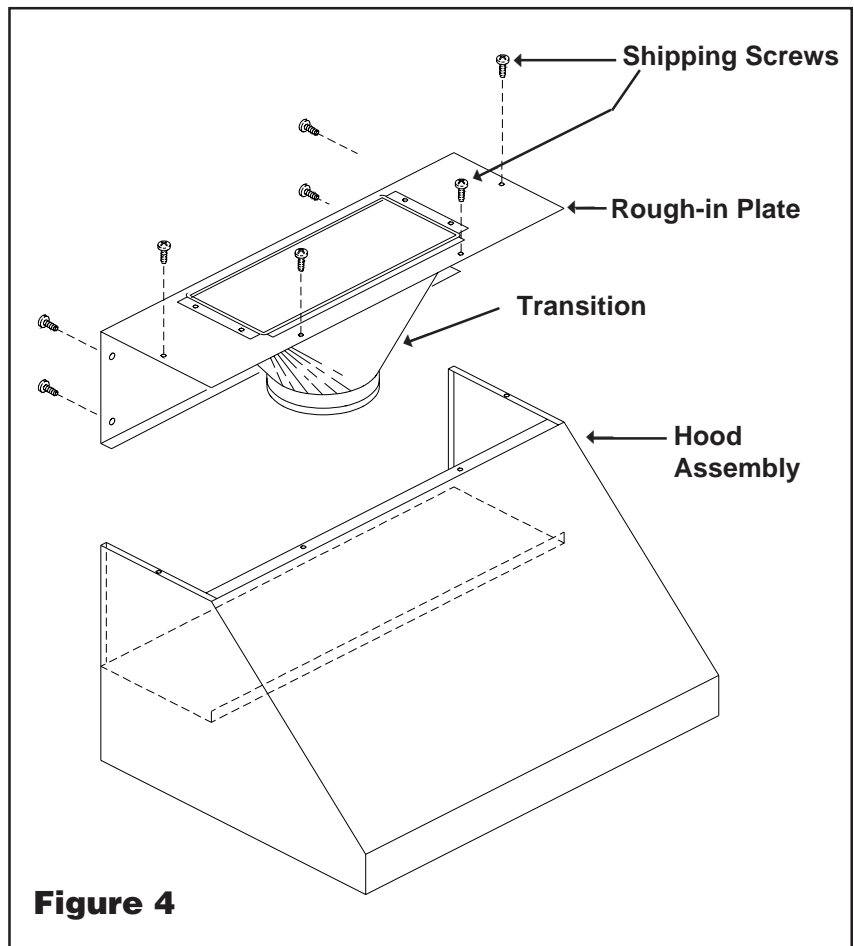

Figure 4

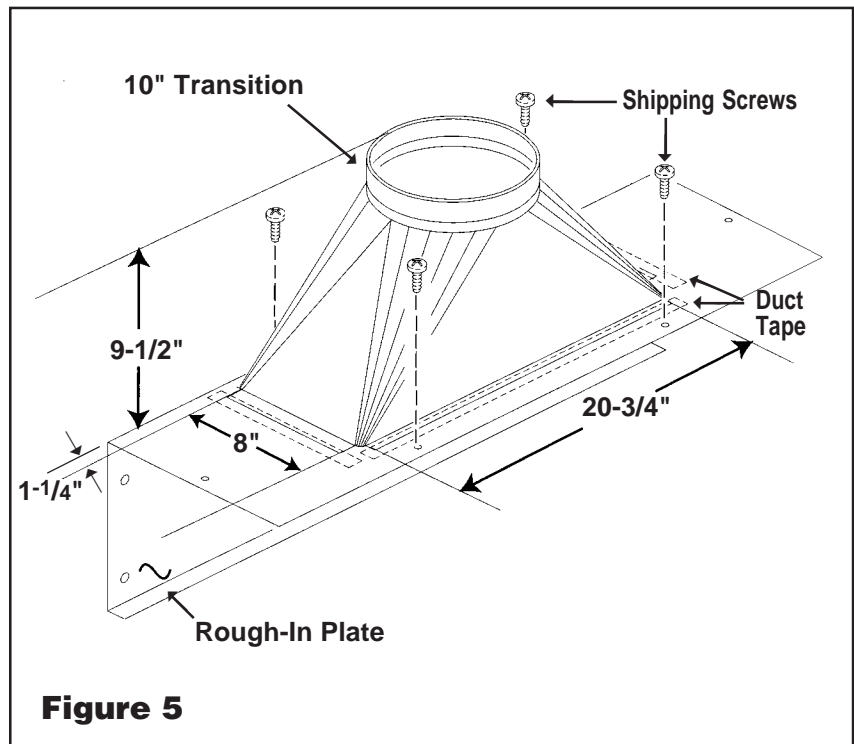

Figure 5

STEP 3. MOUNTING THE INTEGRAL VENTILATOR VTN1000Q

NOTE: Before mounting the VTN1000Q ventilator to the rough-in plate, remove and discard shipping brackets (located on ventilator inlets).

1. Run four (4) #10 x 1" screws (provided) halfway through the rough-in plate into the framing, as shown in Figure 7.
2. Install the ventilator assembly by aligning the four screws on the rough-in plate with the keyholes on the ventilator plate and, at the same time, push the assembly toward the wall. **Make sure all four (4) screws are engaged securely in small end of the keyhole.**
3. Tighten the four screws in the keyholes. **Drive two additional mounting screws on the side of the ventilator plate into the framing.**

CAUTION: — These two additional screws **must** be installed on the ventilator plate.

STEP 4. – DUCTING CONNECTION

1. For internal ventilator, run 10" round duct from the transition (provided) to the wall cap Model #WC 10 (purchased separately).

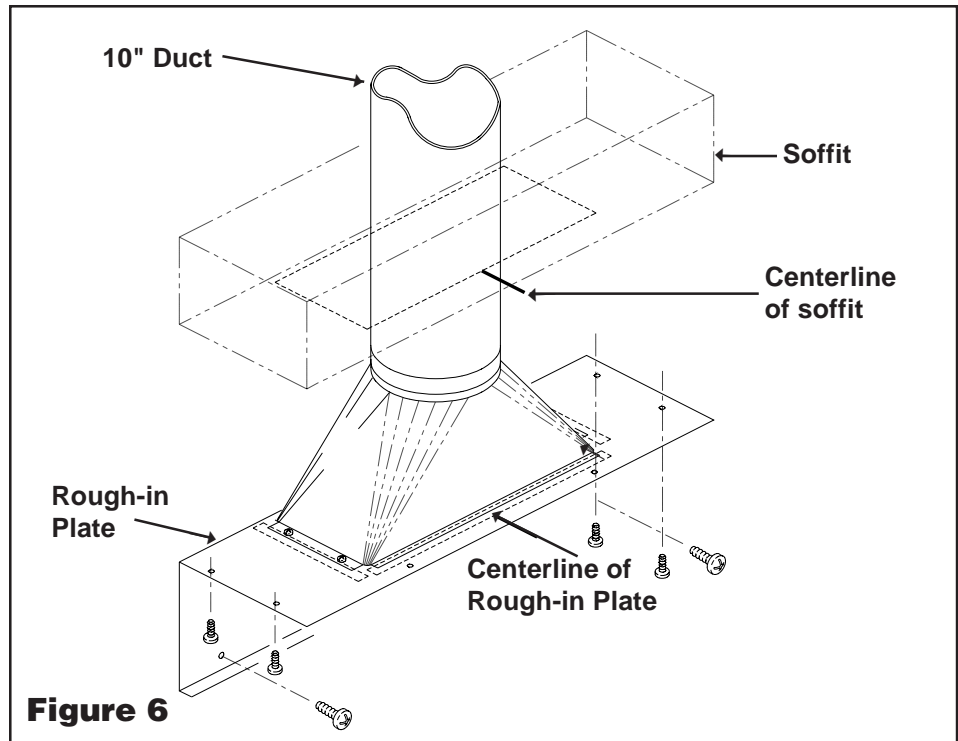

Figure 6

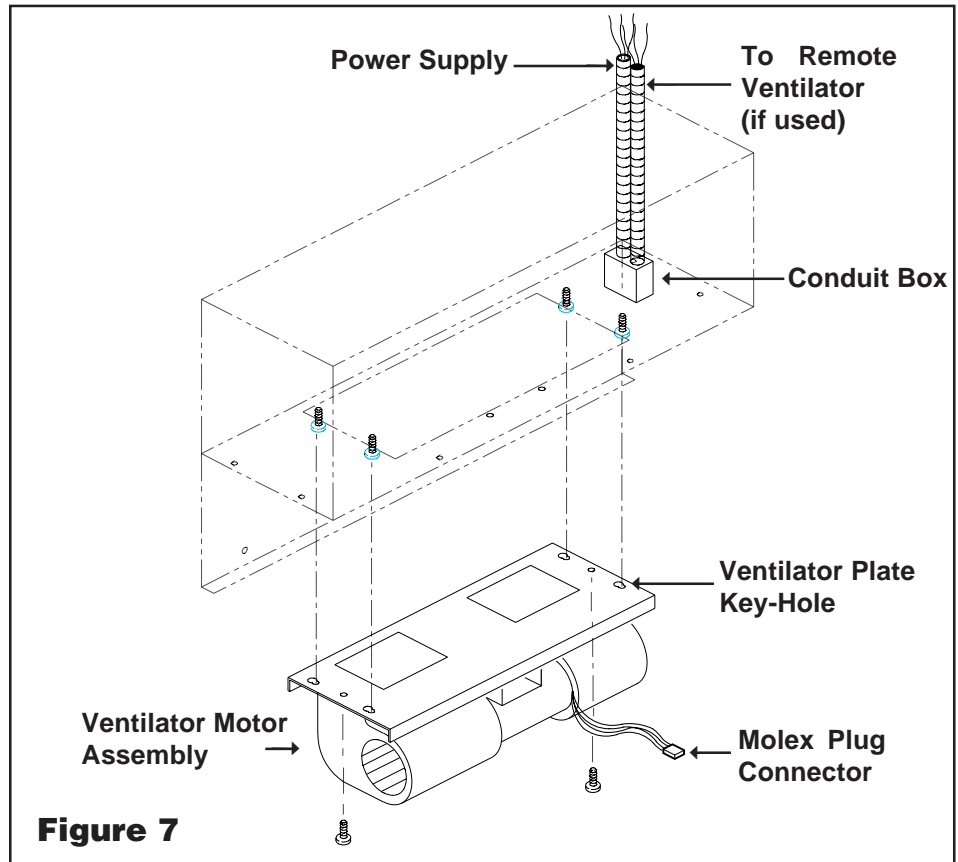

Figure 7

2. For remote ventilator, run 10" round duct from the transition (provided) to the remote ventilator.
3. Duct run should be as short and straight as possible for best performance of ventilator. **SEAL ALL JOINTS WITH DUCT TAPE.**

STEP 5. ELECTRICAL CONNECTION

WARNING: TURN POWER OFF AT SERVICE PANEL AND LOCK PANEL BEFORE WIRING OR SERVICING UNIT.

**Minumim Power Supply Requirement:
120V, 60Hz, 15 Amps**

I WIRING TO POWER SUPPLY:

1. Run supply conduit from service panel to junction box in the rough-in plate. See Figure 8.
2. Remove the knock out and Install the strain relief (conduit) connector on the rough-in plate.
3. Run black, white and green wires (14AWG) through conduit from power supply to junction box.
4. Remove the black wire #23 and white wire #22 from the terminal block and connect to the power supply black and white wires respectively as shown in Figure 8. Connect green wire to power supply ground wire. Use wire nuts approved by UL. Refer to wiring diagram on Page 11 for all connections.

II WIRING TO INTERNAL VENTILATOR MODEL VTN1000Q:

1. Place all wiring connectors inside junction box and reinstall on rough-in plate.
2. Go to STEP 6 on the following page.

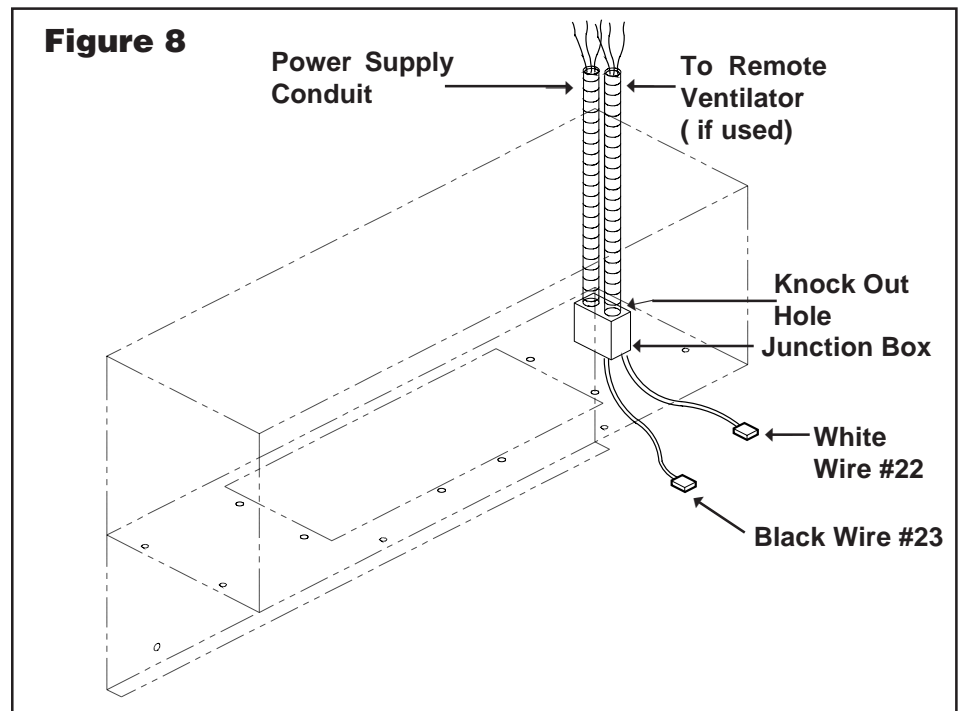

III WIRING TO REMOTE VENTILATOR MODEL VTR1000Q/ VTR1400Q:

1. Run five wires 14 AWG (black, white, blue, red and green) in 1/2" conduit from the remote ventilator to the hood junction box, see Fig.9.
2. Install conduit connector at the end of the conduit. Remove the knockout on top of the rough-in plate. Attach the conduit connector to the rough-in plate.
3. Connect remote ventilator wires to the pig tail assembly

(provided with hood). Use color code method (black to black, white to white, etc.). See Wiring Diagram on page 11.

4. Place all wiring connectors inside junction box and reinstall to rough-in plate.
5. Go to STEP 6 on the following page.

CAUTION: – DO NOT turn power ON until Step 7 is completed.

STEP 6. - INSTALL HOOD ASSEMBLY

1. Align both ends of the hood assembly with the ends of the rough-in plate. Insert the back ends of the hood assembly into the rough-in plate lip and push the hood assembly half way to the wall.
2. Re-install the black wire #23 and white wire #22 to the terminal block.
3. Connect the ventilator plug with hood assembly "Molex" plug connector.
4. Push the hood assembly against the back wall and secure the hood assembly with three (3) screws to the 2" x 4" framing. See Figure 10. Holes are located at the top front of the assembly.
5. Secure the hood rear plate to the drywall through the heat-lamp opening with two (2) screws provided. (Wall anchors are required if the screws will not hit the wall stud.) See Figure 9.

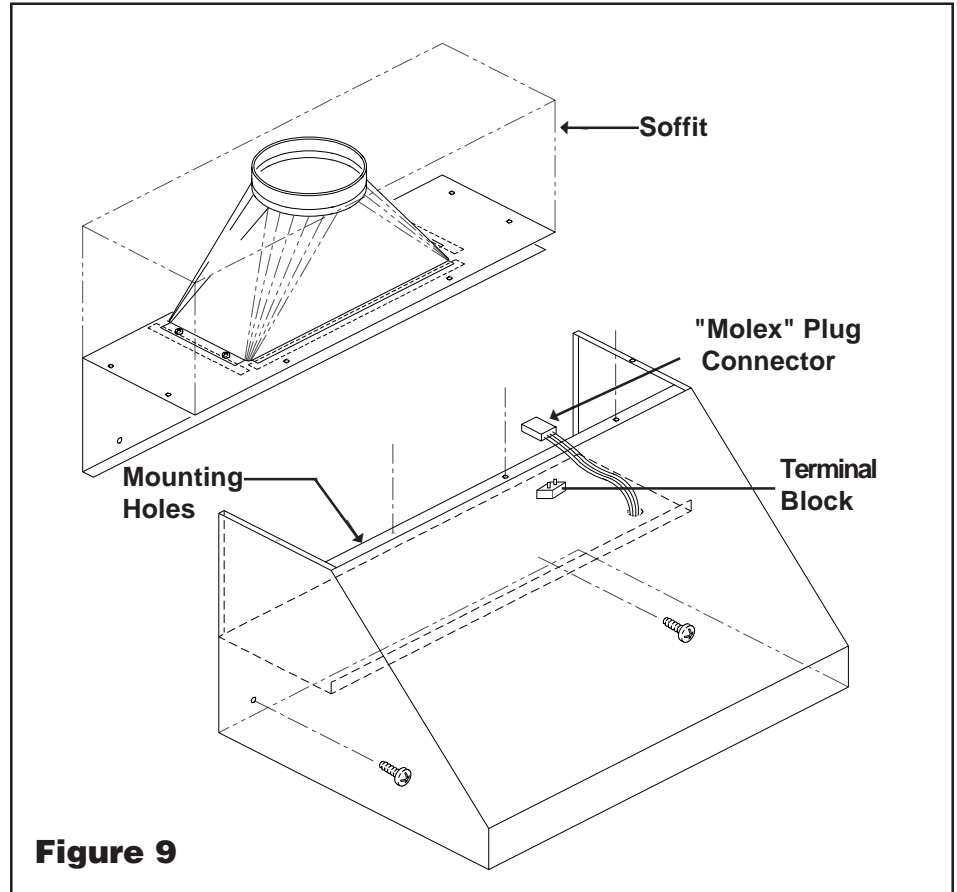

Figure 9

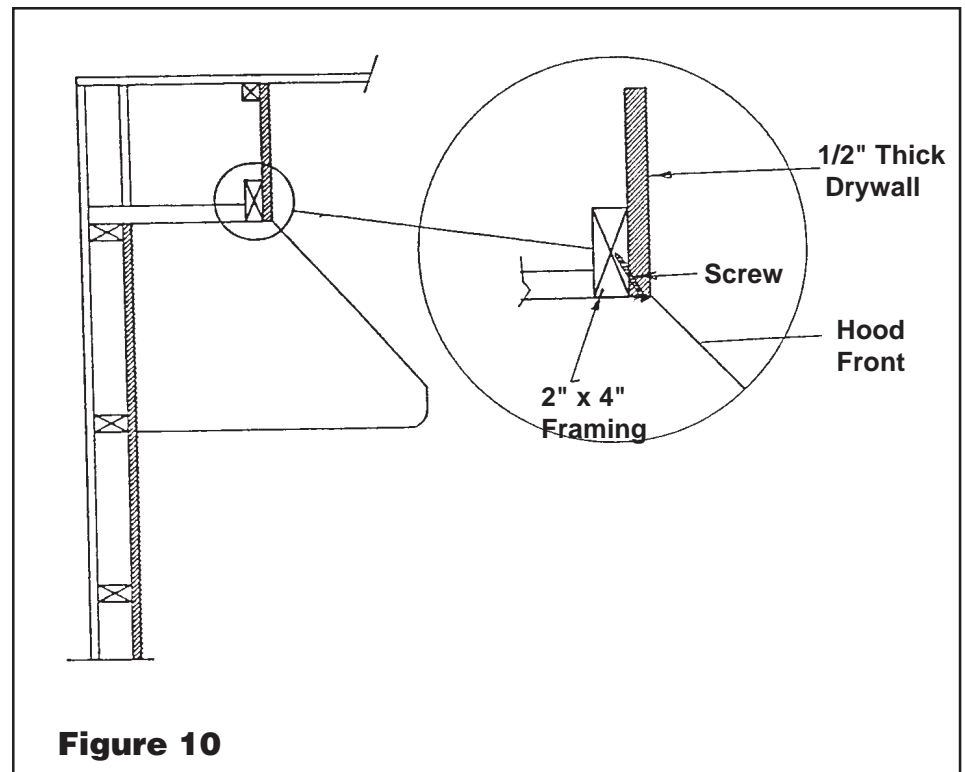
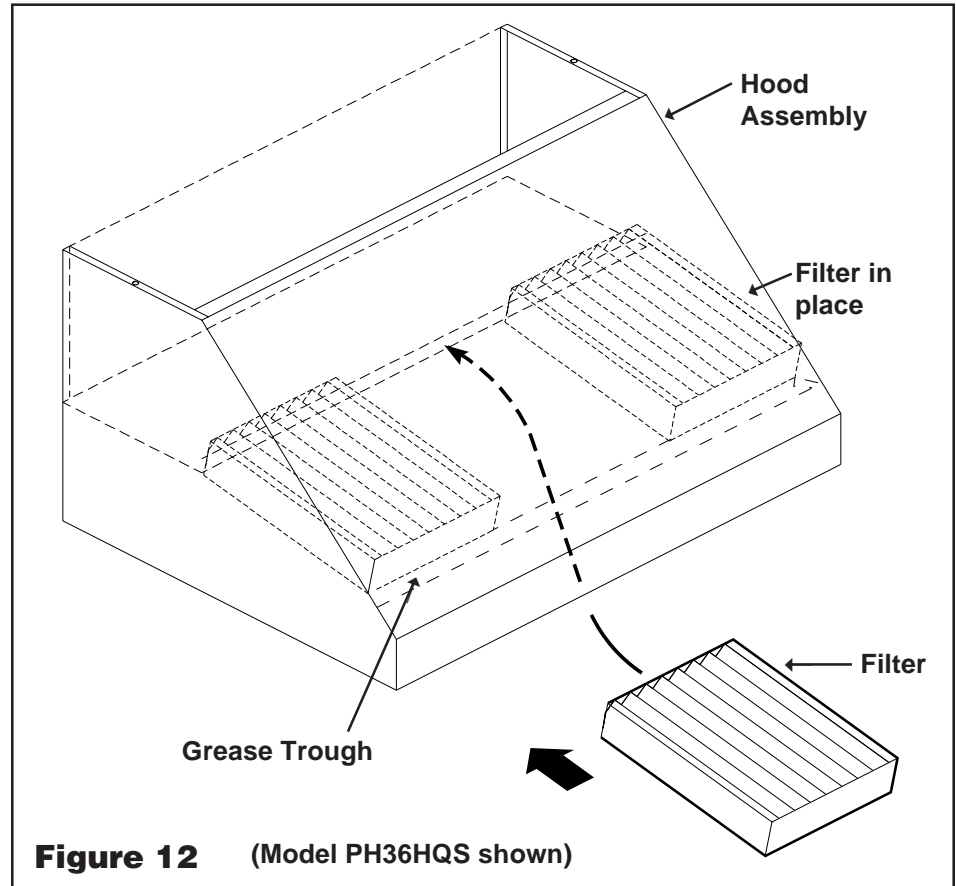

Figure 10

STEP 7. – INSTALL GREASE TROUGHS, FILTERS AND LAMPS

1. Install the grease troughs in the bottom front ledge of the hood assembly.
2. Insert aluminum filter in top ledge of the hood filter opening and fully compress the spring. Raise the bottom edge of the filter and set into grease trough.
3. Install remaining filters as done in Step 2. Install filters in the center of the hood last. See Figure 11.
4. Install two (2) heat lamp bulbs. Use R40 size, 250W Max., infrared bulbs only (purchased separately).
5. Install two (2) halogen light bulbs (48" and 54" models require three (3) light bulbs). Use size R20, 50W Max., narrow flood light (purchased separately).



STEP 8. TURN THE POWER ON AND CHECK THE HOOD OPERATION.

Note: Before turning the power on, make sure the ventilator control is in "OFF" position.

STEP 9. INSTALL KEEP HOT SHELF (OPTIONAL)

See separate Installation Instructions for this unit.

WIRING DIAGRAM 19-11-748

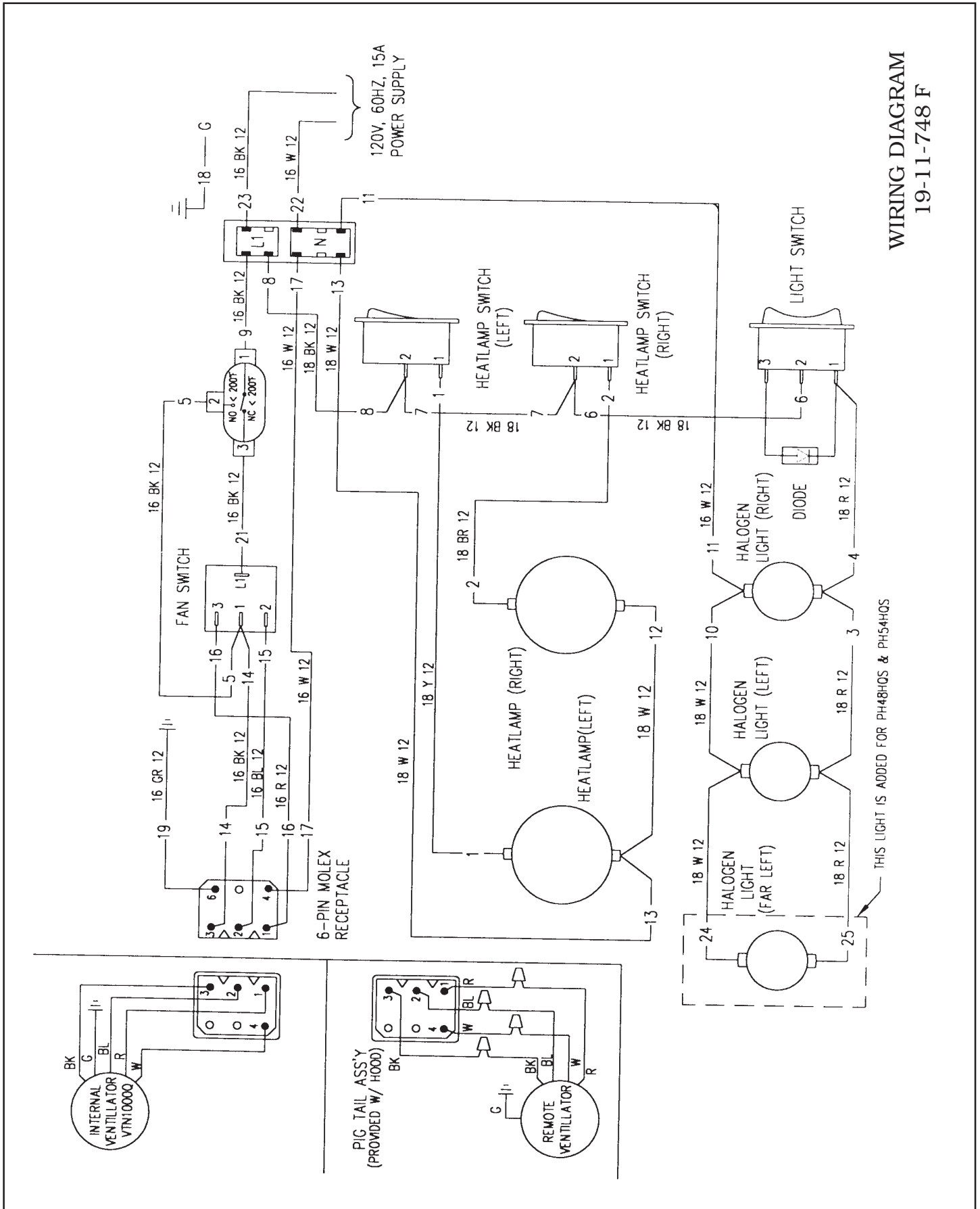

WIRING DIAGRAM
19-11-748 F

THERMADOR® is a leading manufacturer of Convection Micro Thermal Ovens, Convection Thermal Electric Ovens and Ranges, Thermador PROFESSIONAL® Dual-Fuel and All-Gas Ranges, Thermador PROFESSIONAL® Gas Cooktops, Free-Standing and Drop-In/Slide-In Ranges, Warming Drawers, XLO® Gas Cooktops, Traditional Series Gas Cooktops, Glass Ceramic Halogen Cooktops, Glass Ceramic All-Radiant Cooktops, Electric Coil Cooktops, Char-Glo® Indoor Gas Barbecue Grills, Refrigerators, Hoods, Ventilators and Cook'n'Vent® Downdraft Systems.

We reserve the right to change specifications or design without notice. Some models are certified for use in Canada. Thermador is not responsible for products which are transported from the U.S. for use in Canada. Check with your local Canadian distributor or dealer.

Thermador®
C O R P O R A T I O N

5551 McFadden Avenue, Huntington Beach, CA 92649 • 800/735-4328
ECO# 71507 • 19-11-754F • ©Thermador Corporation, 1995 • Litho in U. S. A. 4/99