

PLANNING GUIDE  
VENTILATION

# VENTILATION QUICK REFERENCE CHART

## Quick Reference Chart for Recommended Ventilation Based On Cooking System

MODEL SERIES	Minimum CFM Recommended		Updraft Ventilation Options <sup>1</sup>						Downdraft Ventilation Options <sup>2</sup>			
	Wall	Island	Wall <sup>3</sup>					Island <sup>3</sup>			Cook 'N' Vent <sup>®</sup> Universal for Cooktops	
			HSB	HCSW HSW HTSW HGSW	HS HST	HDW	PH_Z PHE HNW	HGSI	HDI HTDI	PHI_Z HNI HTNI	CVS2	UCV
Gas or Electric Cooktops	300	400	■	■	■	■	■	■	■	■	■	■
30" Downdraft Ranges	600	600										
30" Free-standing or Slide-in Updraft Ranges	400	600	■	■	■	■	■	■	■			
Professional-style Ranges or cooktops for home applications	1000	1400					■			■		

### <sup>1</sup> Updraft Width Guidelines:

The minimum hood width recommended for wall installation equals the cooktop or range width. Where space is not restricted, a wider hood can be used to increase your capture area. Island installations require a greater capture area, therefore the hoods used should overlap your appliance by a minimum of 3"- 6" on either side.

### <sup>2</sup> Cook 'N' Vent 2 Width Guidelines:

The Cook 'N' Vent 2 system selected should match the width of your cooktop. Thermador offers 30", 36" or 45" widths. Due to the high performance requirements of Professional-style appliances for the home, an overhead hood is highly recommended.

### <sup>3</sup> Available Ceiling Height:

Before selecting your updraft hood, check your available installation space. This is determined by adding your floor-to-countertop height, plus the recommended spacing between your appliance and the bottom of the hood, plus the height of the hood. See product dimensions on pages 75-83.

### NOTE:

#### Indoor Gas Grills:

The local codes may require a fire-rated construction for installation of open gas grill appliances. Please check with your local codes prior to installation.

# VENTILATORS

## Integral (Mounted on Hood) Ventilator Options

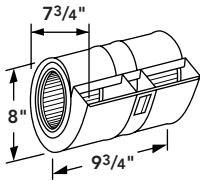
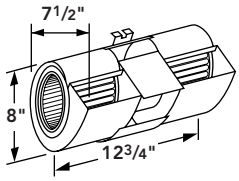
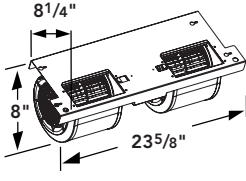
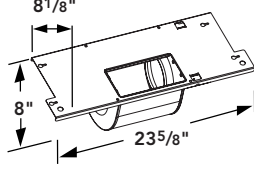
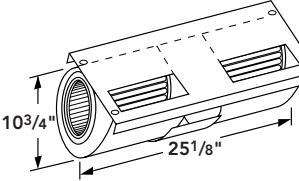
VCK300	VM410	VTN420B	VTN620B	VTN1000Q
				
<b>Maximum CFM:</b> 300	<b>Maximum CFM:</b> 390	<b>Maximum CFM:</b> 400	<b>Maximum CFM:</b> 600	<b>Maximum CFM:</b> 1000
<b>Electrical Motor Rating</b> 2.4 Amps @ 120 V AC, 60 Hz	<b>Electrical Motor Rating</b> 1.5 Amps @ 120 V AC, 60 Hz	<b>Electrical Motor Rating</b> 2.0 Amps @ 120 V AC, 60 Hz	<b>Electrical Motor Rating</b> 4.0 Amps @ 120 V AC, 60 Hz	<b>Electrical Motor Rating</b> 5 Amps @ 120 V AC, 60 Hz
<b>Recommended Duct Size</b> 3 1/4" x 10"	<b>Recommended Duct Size</b> 3 1/4" x 10"	<b>Recommended Duct Size</b> 8" round	<b>Recommended Duct Size</b> 8" round	<b>Recommended Duct Size</b> 10" round
<b>Use in Control Housing</b> VCK1	<b>Use in Control Housing</b> VCH8	<b>Use in Control Housing</b> N/A	<b>Use in Control Housing</b> N/A	<b>Use in Control Housing</b> N/A
<b>Use in Hood Series</b> N/A	<b>Use in Hood Series</b> N/A	<b>Use in Hood Series</b> Standard in HSB Series; option for HS or HST series	<b>Use in Hood Series</b> Option for HS or HST Series	<b>Use in Hood Series</b> Option for PH Series, wall models only

## Remote (Roof or External Wall) Ventilator Options

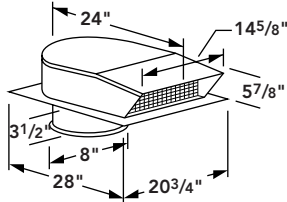
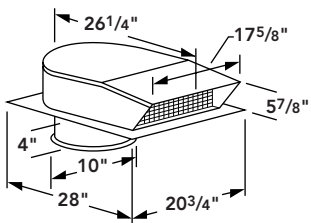
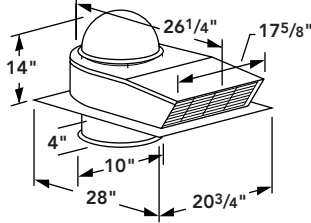
VTR600R	VTR1000Q	VTR1400Q
		
<b>Maximum CFM:</b> 600	<b>Maximum CFM:</b> 1000	<b>Maximum CFM:</b> 1400
<b>Electrical Motor Rating</b> 4.3 Amps @ 120 V AC, 60 Hz	<b>Electrical Motor Rating</b> 7.8 Amps @ 120 V AC, 60 Hz	<b>Electrical Motor Rating</b> 12.8 Amps @ 120 V AC, 60 Hz
<b>Duct Size at Intake</b> 8" round	<b>Duct Size at Intake</b> 10" round	<b>Duct Size at Intake</b> 10" round
<b>Use in Control Housing</b> VCK1, VCH8, VCH36	<b>Use in Control Housing</b> VCH36, VCH54*	<b>Use in Control Housing</b> VCH36, VCH54*
<b>Use in Hood Series</b> Option for HS or HST Series	<b>Use in Hood Series</b> Option for HS, HST, HNI, HNW, HTNI or PH Series	<b>Use in Hood Series</b> Option for HNI, HNW, HTNI, PH or PHI Series
	<b>Note:</b> Heavy-duty backdraft damper included**	<b>Note:</b> Heavy-duty backdraft damper included**

\*When using the VCH54 control housing, you will also need a plenum (Model PLENUM) duct accessory. \*\*No roof jack or wall cap required. Collar extends below mounting flange into roof or wall installation area.



Ventilators are UL and CUL approved.

# CONTROL HOUSINGS FOR CUSTOM HOOD APPLICATIONS

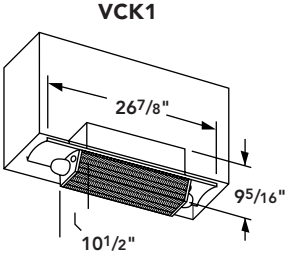
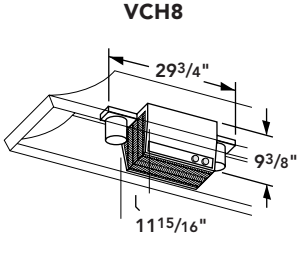
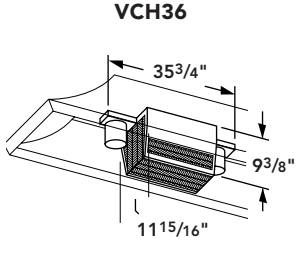
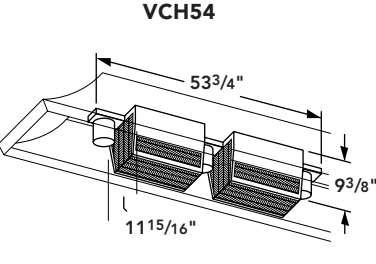
 <p><b>VCK1</b></p>	 <p><b>VCH8</b></p>	 <p><b>VCH36</b></p>	 <p><b>VCH54</b></p>
<p><b>Finish</b> Black enamel with chrome reflector lights</p> <p><b>Application</b> Shallow custom hood or kitchen cabinet</p> <p><b>Lighting</b> Accepts two 60-watt bulbs</p> <p><b>Controls</b> Solid-state infinite speed control and rotary light switch</p> <p><b>Notes:</b></p> <ol style="list-style-type: none"> <li>1. Only 4 1/8" exposed below cabinet cutout.</li> <li>2. Lamps not included.</li> </ol>	<p><b>Finish</b> Satin finish with removable single aluminum mesh filter screens</p> <p><b>Application</b> For nonprofessional-style cooktops/ranges</p> <p><b>Lighting</b> Accepts two 75-watt flood lamps</p> <p><b>Controls</b> Solid-state infinite speed control</p> <p><b>Notes:</b></p> <ol style="list-style-type: none"> <li>1. Filter and lamp shields snap out for easy cleaning.</li> <li>2. Lamps not included.</li> </ol>	<p><b>Finish</b> Satin finish with removable single aluminum mesh filter screen</p> <p><b>Application</b> Use with high heat applications in custom hoods of 36" width or greater</p> <p><b>Lighting</b> Accepts two 75-watt flood lamps</p> <p><b>Controls</b> Requires separate wall-mounted switches* for lights and ventilator</p> <p><b>Notes:</b></p> <ol style="list-style-type: none"> <li>1. Filter and lamp shields snap out for easy cleaning.</li> <li>2. Lamps not included.</li> </ol>	<p><b>Finish</b> Satin finish with removable dual aluminum mesh filter screens</p> <p><b>Application</b> Use with high heat applications in custom hoods of 54" width or greater</p> <p><b>Lighting</b> Accepts three 75-watt flood lamps</p> <p><b>Controls</b> Requires separate wall-mounted switches* for lights and ventilator</p> <p><b>Notes:</b></p> <ol style="list-style-type: none"> <li>1. Filter and lamp shields snap out for easy cleaning.</li> <li>2. Lamps not included.</li> <li>3. Double filter housing for superior performance.</li> <li>4. Requires PLENUM (sold separately from Thermador).</li> </ol>

\*Requires standard wall switch for light, plus Thermador CTRQ-3, three-speed ventilator control switch.

## Recommended Thermador Ventilators\*\*

<p>Internal Mounted VCK300</p> <p>Remote Mounted VTR600R</p>	<p>Internal Mounted VM410</p> <p>Remote Mounted VTR600R</p>	<p>Internal Mounted N/A</p> <p>Remote Mounted VTR600R, VTR1000Q, VTR1400Q</p>	<p>Internal Mounted N/A</p> <p>Remote Mounted VTR1000Q, VTR1400Q</p>
--	---	---	--

\*\*Ventilator performance shown on page 75.



Control Housings are UL and CUL approved.

For immediate critical installation dimensions by fax, use your fax handset and call (775) 833-3600. Use code #8030 for a directory of Thermador® products.

# UPDRAFT VENTILATION

## Professional Series Hoods

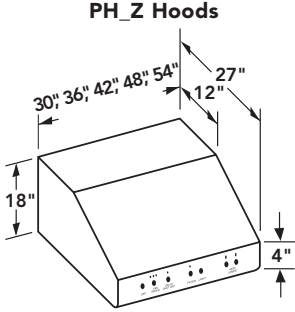
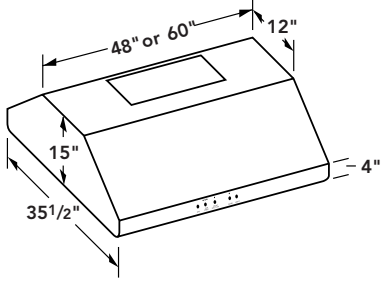
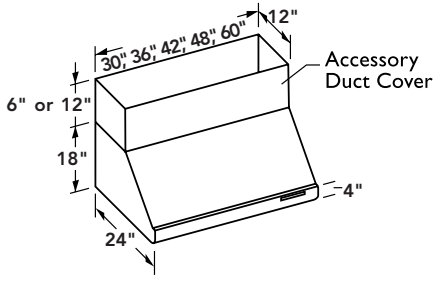
 <p style="text-align: center;"><b>PH_Z Hoods</b></p>	 <p style="text-align: center;"><b>PHI_Z Hoods</b></p>	 <p style="text-align: center;"><b>PHE Hoods</b></p>
<p><b>Installation Type</b> Wall</p> <p><b>Ventilator Options</b> CFM 1000, Integral, Model VTN1000Q CFM 1000, Remote, Model VTR1000Q CFM 1400, Remote, Model VTR1400Q</p> <p><b>Finishes</b> Stainless Steel</p> <p><b>Transition Model Required</b> Included</p> <p><b>Duct Size at Discharge</b> 10" round</p> <p><b>Discharge Direction</b> Vertical or Horizontal</p> <p><b>Electrical Motor Rating</b> VTN1000Q: 5.0 Amps @ 120 V AC, 60 Hz VTR1000Q: 7.8 Amps @ 120 V AC, 60 Hz VTR1400Q: 12.8 Amps @ 120 V AC, 60 Hz</p> <p><b>Hood Lighting Rating</b> 430 watts &amp; 3.6 Amps @ 120 V AC, 60 Hz</p> <p><b>Power Supply</b> 20 Amps (min) @ 120 V AC, 60 Hz</p> <p><b>General Features</b> Double wall construction Dual intensity halogen lighting (2) size G4, 12V, 20W halogen bulbs; 3 bulbs on 48" and 54" widths Two infrared "Keep-Hot" light sockets size PAR-38, 175W, 120V (included), PAR-40, 250W, 120V (optional) Dishwasher-safe commercial-style baffle filters 3-speed electronic controls U.L. approved for damp environments</p> <p><b>Accessory Options</b> "Keep-Hot" Warming Shelf, supports max. weight of 30 lbs., Model KHS, in 30", 36", 42", 48" &amp; 54" widths; wall cap (WC10) for VTN1000Q 12" High Duct Covers, Model DCT in 30", 36", 42" &amp; 48" versions 6" High Duct Covers, Model DC in 30", 36", 42" &amp; 48" versions Remote control for customized installations (cable-connected), Model PHREM (see p. 84)</p> <p><b>Approximate Shipping Weight</b> 30" – 69 lbs.      48" – 98 lbs. 36" – 78 lbs.      54" – 108 lbs. 42" – 88 lbs.</p>	<p><b>Installation Type</b> Island</p> <p><b>Ventilator Options</b> CFM 1400, Remote, Model VTR1400Q</p> <p><b>Finishes</b> Stainless Steel</p> <p><b>Transition Model Required</b> Included</p> <p><b>Duct Size at Discharge</b> 10" round</p> <p><b>Discharge Direction</b> Vertical</p> <p><b>Electrical Motor Rating</b> VTR1400Q: 12.8 Amps @ 120 V AC, 60 Hz</p> <p><b>Hood Lighting Rating</b> 80 watts and .8 Amps @ 120 V AC, 60 Hz</p> <p><b>Power Supply</b> 20 Amps (min) @ 120 V AC, 60 Hz</p> <p><b>General Features</b> Double wall construction Dual intensity halogen lighting (4) size G4, 12V, 20W halogen bulbs (included) Dishwasher-safe commercial-style baffle filters 3-speed electronic controls U.L. approved for damp environments</p> <p><b>Accessory Options</b> Remote control for customized installations (cable-connected), Model PHIREM (see p. 84)</p> <p><b>Approximate Shipping Weight</b> 48" – 98 lbs. 60" – 148 lbs.</p>	<p><b>Installation Type</b> Wall</p> <p><b>Ventilator Options</b> CFM 1000, Integral, Model VTN1000Q CFM 1000, Remote, Model VTR1000Q CFM 1400, Remote, Model VTR1400Q</p> <p><b>Finishes</b> Stainless Steel</p> <p><b>Transition Model Required</b> Included</p> <p><b>Duct Size at Discharge</b> 10" round</p> <p><b>Discharge Direction</b> Vertical or Horizontal</p> <p><b>Electrical Motor Rating</b> VTN1000Q: 5.0 Amps @ 120 V AC, 60 Hz VTR1000Q: 7.8 Amps @ 120 V AC, 60 Hz VTR1400Q: 12.8 Amps @ 120 V AC, 60 Hz</p> <p><b>Hood Lighting Rating</b> 80 watts and .8 Amps @ 120 V AC, 60 Hz</p> <p><b>Power Supply</b> 20 Amps @ 120 V AC, 60 Hz</p> <p><b>General Features</b> Double wall construction Dual intensity halogen lighting (4) size G4, 12V, 20W halogen bulbs (included) Dishwasher-safe aluminum mesh filters 3-speed electronic controls U.L. approved for damp environments Utensil rail standard</p> <p><b>Accessory Options</b> 12" High Duct Covers, Model DCT in 30", 36", 42", 48" &amp; 60" versions 6" High Duct Covers, Model DC in 30", 36", 42", 48" &amp; 60" versions</p> <p><b>Approximate Shipping Weight</b> 30" – 57 lbs. 36" – 64 lbs. 42" – 72 lbs. 48" – 79 lbs. 60" – 95 lbs.</p>



Control Housings are UL and CUL approved.

# UPDRAFT VENTILATION

## Traditional Series Hoods

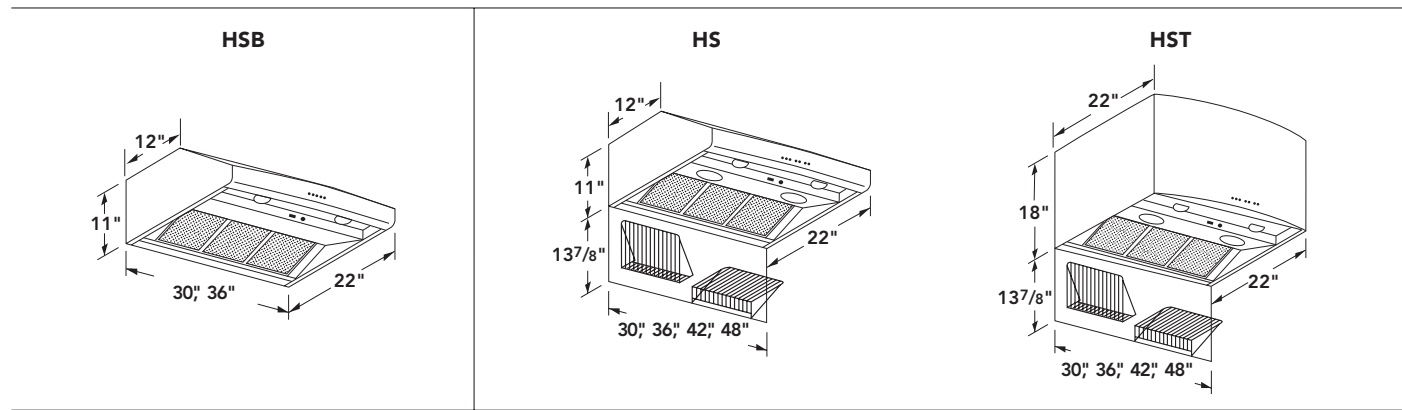

### HSB Hoods

#### Installation Type

Wall

#### Ventilator Options

CFM 400, Integral, supplied with hood

#### Finishes

White or Black Porcelain Enamel,  
Stainless Steel

#### Transition Model Required

Included with hood, which includes  
backdraft damper

#### Duct Size at Discharge

8" round

#### Discharge Direction

Vertical or Horizontal

#### Electrical Motor Rating

1.5 Amps @ 120 V AC, 60 Hz

#### Hood Lighting Rating

100 watts and .8 Amps @ 120 V AC, 60 Hz

#### Power Supply

15 Amps (min) @ 120 V AC, 60 Hz

#### General Features

Double wall construction

Push button controls

Incandescent lighting

Dishwasher-safe aluminum mesh filters

3-Speed blower controls

Includes VTN420B Ventilator

#### Accessory Options

Roof jack or wall cap sold separately at  
most home improvement stores

Accessory duct cover DC, DCT sold  
separately

Recirculation kits available in 30" and 36"  
widths (see p. 84)

Order separately by width and color  
(RECIRC\_\_B\_)

#### Approximate Shipping Weight

30" – 73 lbs.      36" – 78 lbs.

### HS Hoods & HST Hoods (shown with optional KHS)

#### Installation Type

Wall

#### Ventilator Options

CFM 400, Integral,  
Model VTN420B

CFM 600, Integral,  
Model VTN620B

CFM 600, Remote,  
Model VTR600R

CFM 1000, Remote,  
Model VTR100Q

#### Finishes

Stainless Steel

#### Transition Model Required

Included with hood, which includes  
backdraft damper

#### Duct Size at Discharge

8" round

#### Discharge Direction

Vertical or Horizontal

#### Electrical Motor Rating

VTN420B: 2.0 Amps @ 120 V AC, 60 Hz

VTN620B: 4.0 Amps @ 120 V AC, 60 Hz

VTR600R: 4.3 Amps @ 120 V AC, 60 Hz

VTR1000Q: 7.8 Amps @ 120 V AC, 60 Hz

#### Hood Lighting Rating

600 watts and 5.0 Amps @ 120 V AC,  
60 Hz

#### Power Supply

15 Amps (min) @ 120 V AC, 60 Hz

#### General Features

Double wall construction

Electronic controls

Dual-intensity halogen lighting, (2) size  
R20, 50-watt maximum

Two infrared "Keep-Hot" light sockets,  
size R40, 250-watt maximum

Dual-stage, "soft-start" lighting (HST)

Dishwasher-safe aluminum mesh filters

3-speed blower control

Recirculation kits available in 30," 36," 42,"  
48" widths (HS or HSB Models only)  
(see p. 84)

Order separately by width and color  
(RECIRC\_\_B\_)

#### Accessory Options

"Keep-Hot" Warming Shelf, supports  
maximum weight of 30 lbs., Model KHS,  
in 30," 36," 42," 48" & 54" widths

Roof Jack or Wall Cap sold separately at  
most home improvement stores when  
using VTN420B or VTN620B

Telescoping duct cover HSTDTC, sold  
separately (HST)

Accessory duct cover DC, DCT sold  
separately (HS)

#### Approximate Shipping Weight

HS Models:

30" – 55 lbs.

36" – 69 lbs.

42" – 73 lbs.

48" – 83 lbs.

HST Models:

30" – 87 lbs.

36" – 101 lbs.

42" – 110 lbs.

48" – 120 lbs.



Hoods are UL and CUL approved.

For immediate critical installation dimensions by fax, use your fax handset and call (775) 833-3600. Use code #8030 for a directory of Thermador® products.

# UPDRAFT VENTILATION

## Chimney-Style Hoods

### HDW/HNW Chimney-Style Hoods

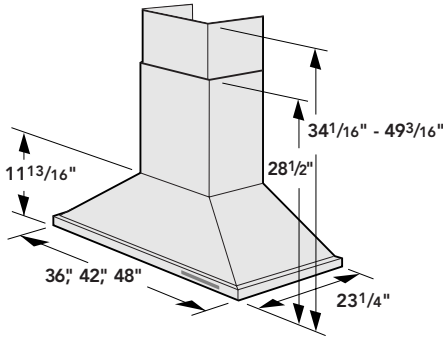

### HDW/HNW Chimney Covers

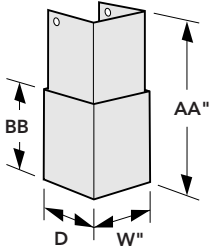

**Installation Type**

Wall

**Ventilator Options**

HDW-CFM 770, Integral, supplied with hood

HNW-CFM 1000 or 1400, Remote, purchase separately

**Finishes**

Stainless Steel

**Transition Model Required**

Included\*

**Duct Size at Discharge**

8" round

**Discharge Direction**

Vertical

**Electrical Motor/Lighting Rating**

HDW36: 4.5 Amps @ 120 V AC, 60 Hz

HDW42/48: 4.9 Amps @ 120 V AC, 60 Hz

**Power Supply**

15 Amps (min.) @ 120 V AC, 60 Hz

**General Features**

Adjustable chimney height at installation

Welded, polished seams

12-volt halogen lighting  
(2 lights in 36", 4 lights in 42" and 48")

Dishwasher-safe aluminum mesh filters

Electronic touch control panel

40-hour clean filter reminder light

10-minute intensive ventilation program

10-minute delayed shutoff

Hood comes complete with filters, lights, backdraft damper and transition

**Accessory Options**

Substitute metal transition (HDTR8-HDW)

(Metal Transition included – HNW)

**Approximate Shipping Weight**

36" – 60 lbs. 42" – 64 lbs. 48" – 73 lbs.

**HDW/HNW**

Width x Depth: 12<sup>15</sup>/<sub>16</sub>" x 9<sup>13</sup>/<sub>16</sub>"

AA (Cover adj. height): 22<sup>3</sup>/<sub>16</sub>" – 38<sup>7</sup>/<sub>16</sub>"

BB (Cover min. height): 17<sup>11</sup>/<sub>16</sub>"

\*An additional transition to 10" round is required for remote blowers and is sold separately at most home improvement stores.



# UPDRAFT VENTILATION

## Chimney-Style Hoods

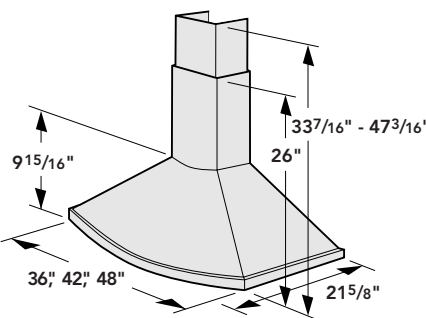
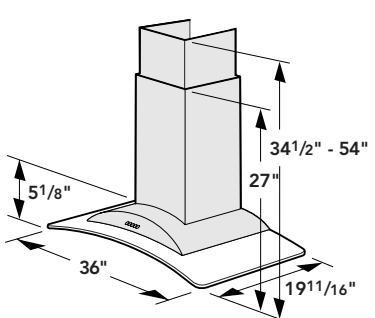
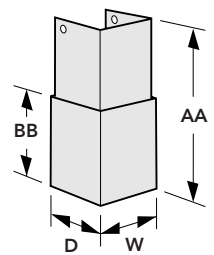
<p style="text-align: center;"><b>HCSW Chimney-Style Hoods</b></p> 	<p style="text-align: center;"><b>HGSW Chimney-Style Hoods</b></p> 	<p style="text-align: center;"><b>HCSW/HGSW Chimney Covers</b></p> 
<p><b>Installation Type</b> Wall</p> <p><b>Ventilator Options</b> CFM 400, Integral, supplied with hood</p> <p><b>Finishes</b> Stainless Steel</p> <p><b>Transition Model Required</b> Included</p> <p><b>Duct Size at Discharge</b> 6" round</p> <p><b>Discharge Direction</b> Vertical or Horizontal</p> <p><b>Electrical Motor/Lighting Rating</b> 2.5 Amps @ 120 V AC, 60 Hz</p> <p><b>Power Supply</b> 15 Amps (min.) @ 120 V AC, 60 Hz</p> <p><b>General Features</b> Adjustable chimney height at installation Welded, polished seams Two 12-volt halogen lights Dishwasher-safe aluminum mesh filters Electronic touch controls 10-minute intensive ventilation program 10-minute delayed shutoff Hood comes complete with filters, lights, backdraft damper and transition</p> <p><b>Accessory Options</b> Substitute metal transition (HSTR6)</p> <p><b>Approximate Shipping Weight</b> 30" – 37 lbs. 36" – 57 lbs. 42" – 62 lbs. 48" – 68 lbs.</p>	<p><b>Installation Type</b> Wall</p> <p>Note: See HGSI for Island version</p> <p><b>Ventilator Options</b> CFM 400, Integral, supplied with hood</p> <p><b>Finishes</b> Stainless Steel with Glass Canopy</p> <p><b>Transition Model Required</b> Included</p> <p><b>Duct Size at Discharge</b> 6" round</p> <p><b>Discharge Direction</b> Vertical or Horizontal</p> <p><b>Electrical Motor/Lighting Rating</b> 2.5 Amps @ 120 V AC, 60 Hz</p> <p><b>Power Supply</b> 15 Amps (min.) @ 120 V AC, 60 Hz</p> <p><b>General Features</b> Adjustable chimney height at installation Welded, polished seams Two 12-volt halogen lights Dishwasher-safe aluminum mesh filters Push button controls Hood comes complete with filters, lights, backdraft damper and transition</p> <p><b>Accessory Options</b> Substitute metal transition (HGTR6)</p> <p><b>Approximate Shipping Weight</b> 36" – 88 lbs.</p>	<p><b>HCSW</b> Width x Depth: 8<sup>3</sup>/<sub>16</sub>" x 6<sup>7</sup>/<sub>8</sub>" AA (Cover adj. height): 23<sup>7</sup>/<sub>16</sub>" x 37<sup>5</sup>/<sub>8</sub>" BB (Cover min. height): 16"</p> <p><b>HGSW</b> Width x Depth: 11<sup>3</sup>/<sub>4</sub>" x 11<sup>3</sup>/<sub>4</sub>" AA (Cover adj. height): 29<sup>5</sup>/<sub>16</sub>" – 50<sup>1</sup>/<sub>4</sub>" BB (Cover min. height): 21<sup>13</sup>/<sub>16</sub>"</p>



Hoods and Chimney Covers are UL and CUL approved.

For immediate critical installation dimensions by fax, use your fax handset and call (775) 833-3600. Use code #8030 for a directory of Thermador® products.

# UPDRAFT VENTILATION

## Chimney-Style Hoods

### HTSW Chimney-Style Hoods

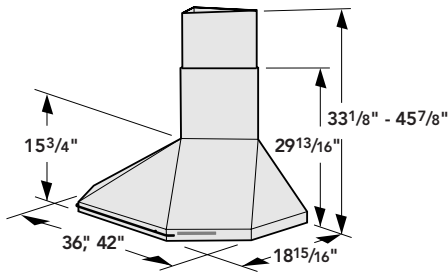

### HGSI Chimney-Style Hoods

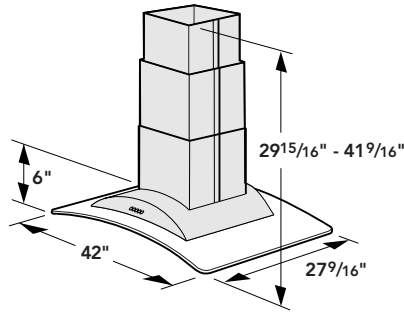

### HTSW/HGSI Chimney Covers

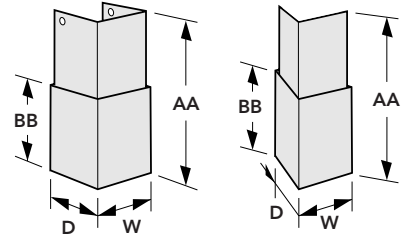

#### Installation Type

Wall  
Note: See HTDI for Island version

#### Ventilator Options

CFM 400, Integral, supplied with hood

#### Finishes

Stainless Steel

#### Transition Model Required

Included

#### Duct Size at Discharge

6" round

#### Discharge Direction

Vertical or Horizontal

#### Electrical Motor/Lighting Rating

2.5 Amps @ 120 V AC, 60 Hz

#### Power Supply

15 Amps (min.) @ 120 V AC, 60 Hz

#### General Features

Adjustable chimney height at installation  
Welded, polished seams  
Two 12-volt halogen lights  
Dishwasher-safe aluminum mesh filters  
Electronic touch controls  
40-hour clean filter reminder light  
10-minute intensive ventilation program  
10-minute delayed shutoff  
Polished chrome rail

Hood comes complete with filters, lights, backdraft damper and transition

#### Accessory Options

Substitute metal transition (HGTR6)

#### Approximate Shipping Weight

36" – 57 lbs.  
42" – 68 lbs.

#### Installation Type

Island  
Note: See HGSI for Wall version

#### Ventilator Options

CFM 400, Integral, supplied with hood

#### Finishes

Stainless Steel with Glass Canopy

#### Transition Model Required

Included

#### Duct Size at Discharge

6" round

#### Discharge Direction

Vertical

#### Electrical Motor/Lighting Rating

3 Amps @ 120 V AC, 60 Hz

#### Power Supply

15 Amps (min.) @ 120 V AC, 60 Hz

#### General Features

Adjustable chimney height at installation  
Welded, polished seams  
Four 12-volt halogen lights  
Dishwasher-safe aluminum mesh filters  
Push-button controls

Hood comes complete with filters, lights, backdraft damper and transition

#### Accessory Options

Substitute metal transition (HGTR6)

#### Approximate Shipping Weight

42" – 132 lbs.

#### HTSW

Width x Depth: 15<sup>7</sup>/<sub>16</sub>" x 10<sup>5</sup>/<sub>16</sub>"  
AA (Cover adj. height): 17<sup>5</sup>/<sub>16</sub>" x 30<sup>3</sup>/<sub>16</sub>"  
BB (Cover min. height): 14"

#### HGSI

Width x Depth: 11<sup>3</sup>/<sub>4</sub>" x 11<sup>3</sup>/<sub>4</sub>"  
AA (Cover adj. height): 25<sup>1</sup>/<sub>4</sub>" – 32<sup>15</sup>/<sub>16</sub>"  
BB (Cover min. height): N/A



# UPDRAFT VENTILATION

## Chimney-Style Hoods

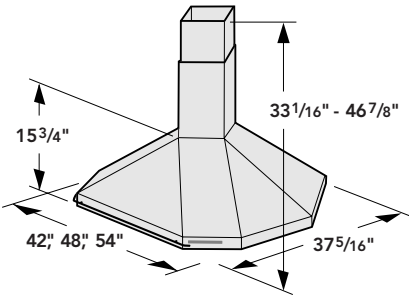
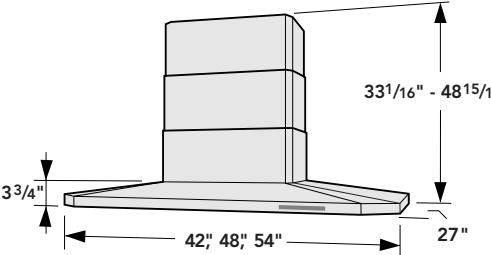
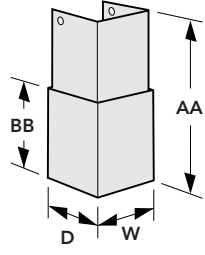
<p style="text-align: center;"><b>HTNI Chimney-Style Hoods</b></p> 	<p style="text-align: center;"><b>HDI/HNI Chimney-Style Hoods</b></p> 	<p style="text-align: center;"><b>HDI/HNI Chimney Covers</b></p> 
<p><b>Installation Type</b> Island Note: See HTSW for Wall version</p> <p><b>Ventilator Options</b> HTNI-CFM 1000, or 1400 Remote, purchase separately</p> <p><b>Finishes</b> Stainless Steel</p> <p><b>Transition Model Required</b> Included*</p> <p><b>Duct Size at Discharge</b> 8" round</p> <p><b>Discharge Direction</b> Vertical</p> <p><b>Electrical Motor/Lighting Rating</b> 4.5 Amps @ 120 V AC, 60 Hz</p> <p><b>Power Supply</b> 15 Amps (min.) @ 120 V AC, 60 Hz</p> <p><b>General Features</b> Adjustable chimney height at installation Welded, polished seams Four 12-volt halogen lights Dishwasher-safe aluminum mesh filters Electronic touch control panel 40-hour clean filter reminder light 10-minute intensive ventilation program 10-minute delayed shutoff Polished chrome rail Hood comes complete with filters, lights, backdraft damper and transition</p> <p><b>Accessory Options</b> Substitute metal transition (HDTR8-HTDI) (Metal transition included – HTNI)</p> <p><b>Approximate Shipping Weight</b> 42" – 99 lbs. 48" – 115 lbs. 54" – 128 lbs.</p>	<p><b>Installation Type</b> Island</p> <p><b>Ventilator Options</b> HDI-CFM 770, Integral, supplied with hood HNI-CFM 1000 or 1400, Remote, purchase separately</p> <p><b>Finishes</b> Stainless Steel</p> <p><b>Transition Model Required</b> Included*</p> <p><b>Duct Size at Discharge</b> 8" round</p> <p><b>Discharge Direction</b> Vertical</p> <p><b>Electrical Motor/Lighting Rating</b> 4.9 Amps @ 120 V AC, 60 Hz</p> <p><b>Power Supply</b> 15 Amps (min.) @ 120 V AC, 60 Hz</p> <p><b>General Features</b> Adjustable chimney height at installation Welded, polished seams Compact fluorescent lights Dishwasher-safe aluminum mesh filters Electronic touch control panel 40-hour clean filter reminder light 10-minute intensive ventilation program 10-minute delayed shutoff Hood comes complete with filters, lights, backdraft damper and transition</p> <p><b>Accessory Options</b> Substitute metal transition (HDTR8-HDI) (Metal transition included – HNI)</p> <p><b>Approximate Shipping Weight</b> 42" – 86 lbs. 48" – 97 lbs. 54" – 104 lbs.</p>	<p><b>HTDI/HTNI</b> Width x Depth: 11" x 11" AA (Cover adj. height): 17<sup>15</sup>/<sub>16</sub>" – 31<sup>1</sup>/<sub>8</sub>" BB (Cover min. height): N/A</p> <p><b>HDI/HNI</b> Width x Depth: 19<sup>11</sup>/<sub>16</sub>" x 15<sup>13</sup>/<sub>16</sub>" AA (Cover adj. height): 29<sup>5</sup>/<sub>16</sub>" x 45<sup>3</sup>/<sub>16</sub>" BB (Cover min. height): N/A</p>

\*An additional transition to 10" round is required for remote blowers and is sold separately at most home improvement stores.



Hoods and Chimney Covers are UL and CUL approved.

For immediate critical installation dimensions by fax, use your fax handset and call (775) 833-3600. Use code #8030 for a directory of Thermador® products.

# DOWNDRAFT VENTILATION

## Cook 'N' Vent® System

Cook 'N' Vent (CVS2) Intake

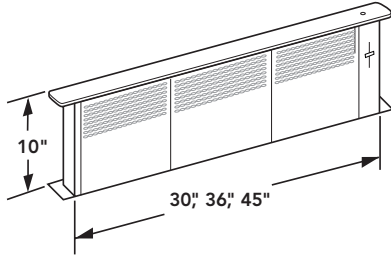

Universal Cook 'N' Vent (UCV) Intake

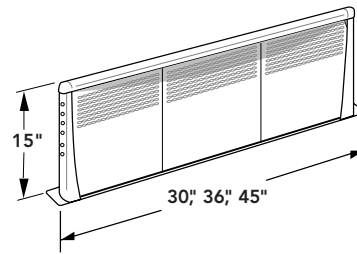

### Installation Type

Wall\* or Island

### Dimensions

Available Widths: 30", 36" or 45"

### Ventilator Options

CFM 600, Integral, Model VTN600CVS2 (CVS2 models)  
 CFM 600, Integral, Model VTN600CVA (UCV models)  
 CFM 600, Remote, Model VTR600R (CVS2 or UCV models)  
 CFM 1000, Remote, Model VTR1000Q (CVS2 or UCV models)

### Finishes (Top Cap only)

White or Black Porcelain Enamel, Stainless Steel

### Transition Model Required/Duct Size at Discharge

Must order one of the following for all remote ventilator installations:

CVS2: CV2T6 – Transition to 6" round duct  
 UCV: CVT7 – Transition to 7" round duct  
 CVT314 – Transition to 3<sup>1</sup>/<sub>4</sub>" x 14" duct

### Discharge Direction

Straight Down, Left or Right

### Electrical Motor Rating

10.2 Amps @ 120 V AC, 60 Hz

### Power Supply

15 amps (min.) @ 120 V AC, 60 Hz

### General Features

Universal Cook 'N' Vent intakes are designed for installation with all nonprofessional-style cooktops

Top cap design color-matched to black, white and stainless steel cooktops

Single-touch up/down control for intake

Easy-to-remove, dishwasher-safe aluminum mesh filters

### CVS Features:

Recessed infinite speed control is visible only when intake is in raised position

Raises 10" when in use

### UCV Features:

Raises 15" when in use

Electronic controls

Delayed shut-off

Clean filter reminder

Full-face filters

### Accessory Options

Ventilators and duct transitions stated

### Approximate Shipping Weight

30" – 55 lbs. 36" – 61 lbs. 45" – 70 lbs.

\* Requires minimum of 24" deep cabinet

## Cook 'N' Vent Ventilator Options

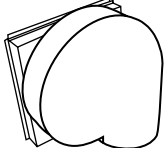
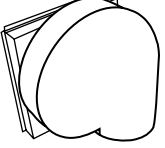
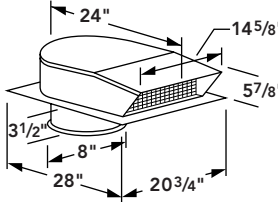
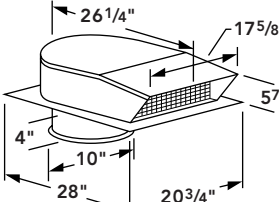
VTN600CV2C	VTN600CVA	VTR600R†	VTR1000Q†
 <p><b>Maximum CFM:</b> 600  <b>Electrical Motor Rating</b>                      3.4 Amps @ 120 V AC, 60 Hz  <b>Duct Size at Discharge</b>                      6" round  <b>Transition Models</b>                      N/A  <b>Usable with Updraft Hood</b>                      No  <b>Note:</b> Backdraft damper (RJ310) or wall cap (WC310) required.</p>	 <p><b>Maximum CFM:</b> 600  <b>Electrical Motor Rating</b>                      3.4 Amps @ 120 V AC, 60 Hz  <b>Duct Size at Discharge</b>                      6" round  <b>Transition Models</b>                      N/A  <b>Usable with Updraft Hood</b>                      No</p>	 <p><b>Maximum CFM:</b> 600  <b>Electrical Motor Rating</b>                      4.3 Amps @ 120 V AC, 60 Hz  <b>Duct Size at Ventilator</b>                      8" round  <b>Transition Models**</b>                      CVS: CVD310 (3<sup>1</sup>/<sub>4</sub>" x 10")                      CVD314 (3<sup>1</sup>/<sub>4</sub>" x 14")                      UCV: CVT7 (7" round)                      CVT314 (3<sup>1</sup>/<sub>4</sub>" x 14")  <b>Usable with Updraft Hood</b>                      Yes</p>	 <p><b>Maximum CFM:</b> 1000  <b>Electrical Motor Rating</b>                      7.8 Amps @ 120 V AC, 60 Hz  <b>Duct Size at Ventilator</b>                      10" round  <b>Transition Models**</b>                      CVS: CVD310 (3<sup>1</sup>/<sub>4</sub>" x 10")                      CVD314 (3<sup>1</sup>/<sub>4</sub>" x 14")                      UCV: CVT7 (7" round)                      CVT314 (3<sup>1</sup>/<sub>4</sub>" x 14")  <b>Usable with Updraft Hood</b>                      Yes</p>

\*\*Requires one of the transitions stated for proper installation and a secondary transition to duct size.

†No roof jack or wall cap required. Collar on Ventilator extends below mounting flange into roof or wall installation area.

# VENTILATION

## Accessories

### Remote Control Panel for Customized Installations

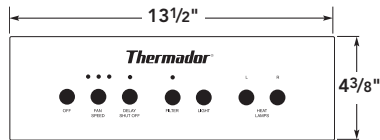

### Telescoping Duct Cover

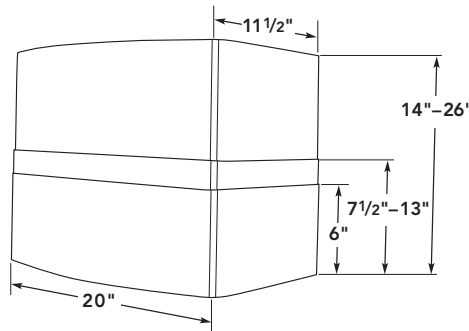

### Recirculation Kit

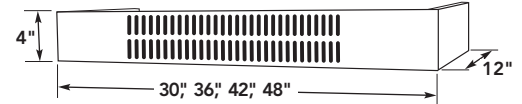

### For Customized Installations

#### Available for Professional Series Models:

PH\_Z (Wall Installation):  
Model PHREM

PHI\_Z (Island Installation):  
Model PHIREM

#### Connection to Ventilator and Hood Controls:

Cable-connected

#### Approximate Shipping Weight

PHREM – 3 lbs.  
PHIREM – 3 lbs.

#### Cutout Size

3 3/8" x 11 1/4"

### For Use with HST Series Hoods

**Fits all HST Sizes**  
(30", 36", 42", 48")

#### Approximate Shipping Weight

30" – 17 lbs.  
36" – 17 lbs.  
42" – 17 lbs.  
48" – 17 lbs.

### For Use with HS and HSB Series Hoods

#### Finishes

White

30" – RECIRC30BW

36" – RECIRC36BW

Black

30" – RECIRC30BB

36" – RECIRC36BB

Stainless Steel

30" – RECIRC30BS

36" – RECIRC36BS

42" – RECIRC42BS

48" – RECIRC48BS

#### Approximate Shipping Weight

30" – 13 lbs.

36" – 16 lbs.

42" – 18 lbs.

48" – 21 lbs.

### Chimney Cover

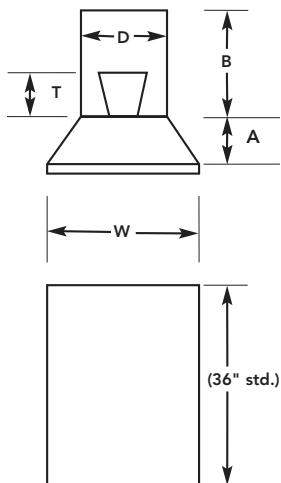

### For Use with Professional Series Island Hoods (PHI\_Z)

#### PHICHIM Height (B)

PHICHIM15 (Min to Max): 9 1/4" – 14 1/4"

PHICHIM27 (Min to Max): 15" – 21"

PHICHIM51 (Min to Max): 27" – 51"

#### Canopy Height (A)

15"

#### Transition Height (T)

10"

#### Hood Width (W)

PHI48ZS: 48"

PHI60ZS: 60"

#### Chimney Depth (D)

10"

#### Duct Size

10" Diameter

#### Approximate Shipping Weight

83 lbs.



All refrigerators are UL and CUL approved.

For immediate critical installation dimensions by fax, use your fax handset and call (775) 833-3600. Use code #8030 for a directory of Thermador® products.